

DECLARATION OF PERFORMANCE

DoP 0179

for fischer Zykon- Anchor FZA, FZA-D, FZA-I, FZA ST (Mechanical anchor for use in concrete)

EN

1. <u>Unique identification code of the product-type:</u>	DoP 0179		
2. <u>Intended use/es:</u>	Post-installed fastening in cracked or uncracked concrete. See appendix, especially annexes B1- B5		
3. <u>Manufacturer:</u>	fischerwerke GmbH & Co. KG, Klaus-Fischer-Str. 1, 72178 Waldachtal, Germany		
4. <u>Authorised representative:</u>	–		
5. <u>System/s of AVCP:</u>	1		
6. <u>European Assessment Document:</u>	EAD 330232-01-0601, (Edition 12/ 2019)		
European Technical Assessment:	ETA-98/0004; 2020-02-18		
Technical Assessment Body:	DIBt- Deutsches Institut für Bautechnik		
Notified body/ies:	1343 MPA Darmstadt / 2873 TU Darmstadt		
7. <u>Declared performance/s:</u>			
Mechanical resistance and stability (BWR 1)			
Characteristic resistance to tension load (static and quasi-static loading):	Resistance to steel failure: Resistance to pull- out failure:	Annexes C1-C3 Annexes C1-C3	E _s = 210 000 MPa
	Resistance to concrete cone failure: Robustness:	Annexes C1-C3 Annexes C1-C3	
	Minimum edge distance and spacing: Edge distance to prevent splitting under load:	Annex C7 Annexes C1- C3	
Characteristic resistance to shear load (static and quasi-static loading), Method A:	Resistance to steel failure (shear load): Resistance to pry-out failure:	Annexes C4- C6 Annexes C4- C6	
Characteristic resistance and displacements for seismic performance categories C1 and C2:	Resistance to tension load, displacements, category C1: Resistance to tension load, displacements, category C2: Resistance to shear load, displacements, category C1: Resistance to shear load, displacements, category C2: Factor for annular gap:	Annexes C8, C9 Annexes C10, C11, C15 Annexes C8, C9 Annexes C10, C11, C15 Annexes C8- C11	
Characteristic Resistance for simplified design:	Method B: Method C:	NPD NPD	
Displacements and durability:	Displacements under static and quasi-static loading: Durability:	Annexes C14, C15 Annexes A7, B1	
Safety in case of fire (BWR 2)			
Reaction to fire:	Class (A1)		
Resistance to fire:	Fire resistance to steel failure (tension load): Fire resistance to pull-out failure (tension load): Fire resistance to steel failure (shear load):	Annexes C12, C13 Annexes C12, C13 Annexes C12, C13	



8. Appropriate Technical Documentation and/or Specific –
Technical Documentation:

The performance of the product identified above is in conformity with the set of declared performance/s. This declaration of performance is issued, in accordance with Regulation (EU) No 305/2011, under the sole responsibility of the manufacturer identified above.

Signed for and on behalf of the manufacturer by:

Thilo Pregartner, Dr.-Ing.
Tumlingen, 2020-03-03

Peter Schillinger, Dipl.-Ing.

This DoP has been prepared in different languages. In case there is a dispute on the interpretation the English version shall always prevail.

The Appendix includes voluntary and complementary information in English language exceeding the (language-neutrally specified) legal requirements.

Specific Part

1 Technical description of the product

The fischer-Zykon-Anchor FZA, FZA-D, FZA-I and FZA ST is an anchor made of galvanised or stainless or high corrosion resistant steel which is placed in an undercut hole and anchored by mechanical interlock with displacement-controlled installation.

The bolt projection anchor FZA and the through bolt anchor FZA-D consists of a conical bolt with external thread, an expansion sleeve and a hexagon nut with washer. The internal threaded anchor FZA-I consists of a conical bolt with internal thread and an expansion sleeve. The bold projecting anchor FZA ST consists of a conical bolt with hexagon projecting end, an expansion sleeve with colour marking, a hexagon nut with washer and a plastic sleeve.

The anchor is anchored by impact acting on the expansion sleeve over the cone bolts in the undercuts of the borehole.

The product description is given in Annex A.

2 Specification of the intended use in accordance with the applicable European Assessment Document

The performances given in Section 3 are only valid if the fastener is used in compliance with the specifications and conditions given in Annex B.

The verifications and assessment methods on which this European Technical Assessment is based lead to the assumption of a working life of the fastener of at least 50 years. The indications given on the working life cannot be interpreted as a guarantee given by the producer, but are to be regarded only as a means for choosing the right products in relation to the expected economically reasonable working life of the works.

3 Performance of the product and references to the methods used for its assessment

3.1 Mechanical resistance and stability (BWR 1)

Essential characteristic	Performance
Characteristic resistance to tension load (static and quasi-static loading)	See Annex C1 to C3, Annex C7
Characteristic resistance to shear load (static and quasi-static loading)	See Annex C4 to C6
Displacements (static and quasi-static loading)	See Annex C14 to C15
Durability	See Annex B1
Characteristic resistance and displacements for seismic performance categories C1 and C2	See Annex C8 to C11

3.2 Safety in case of fire (BWR 2)

Essential characteristic	Performance
Reaction to fire	Class A1
Resistance to fire	See Annex C12 to C13

4 Assessment and verification of constancy of performance (AVCP) system applied, with reference to its legal base

In accordance with the European Assessment Document EAD 330232-01-0601 the applicable European legal act is: [96/582/EC].

The system to be applied is: 1

Bolt projecting anchor FZA:

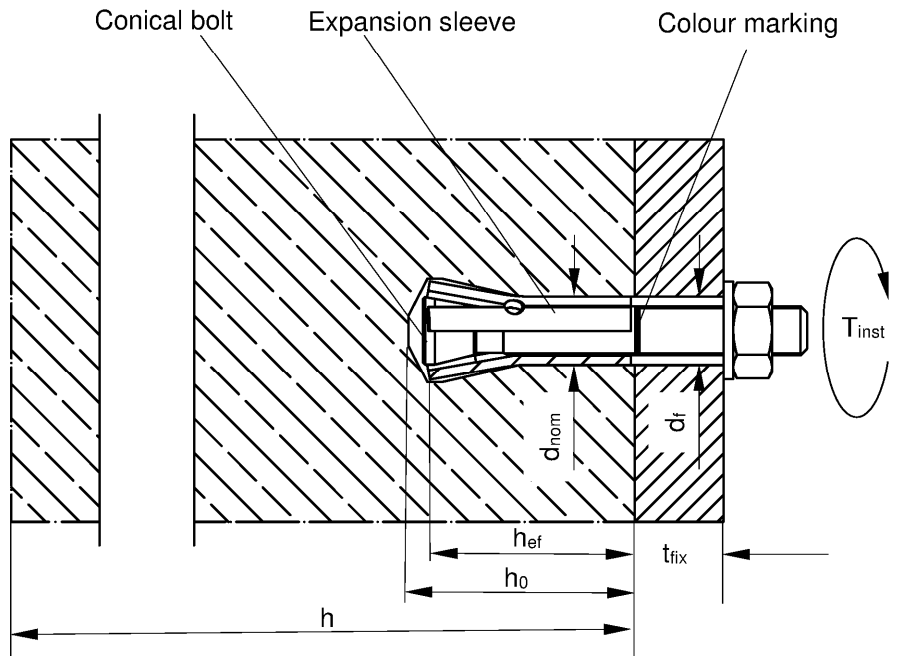

Through bolt anchor FZA D:

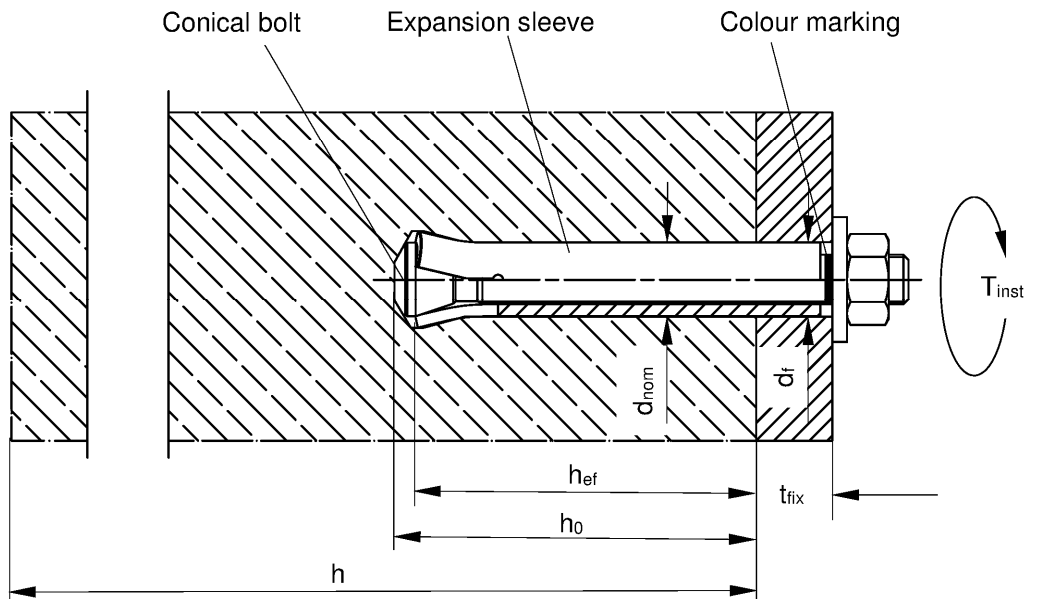

(figure not to scale)

fischer-Zykon-Anchor FZA, FZA D, FZA I, FZA ST

Product description
Installed condition

Annex A1

Appendix 3/ 29

Internal thread anchor FZA I:

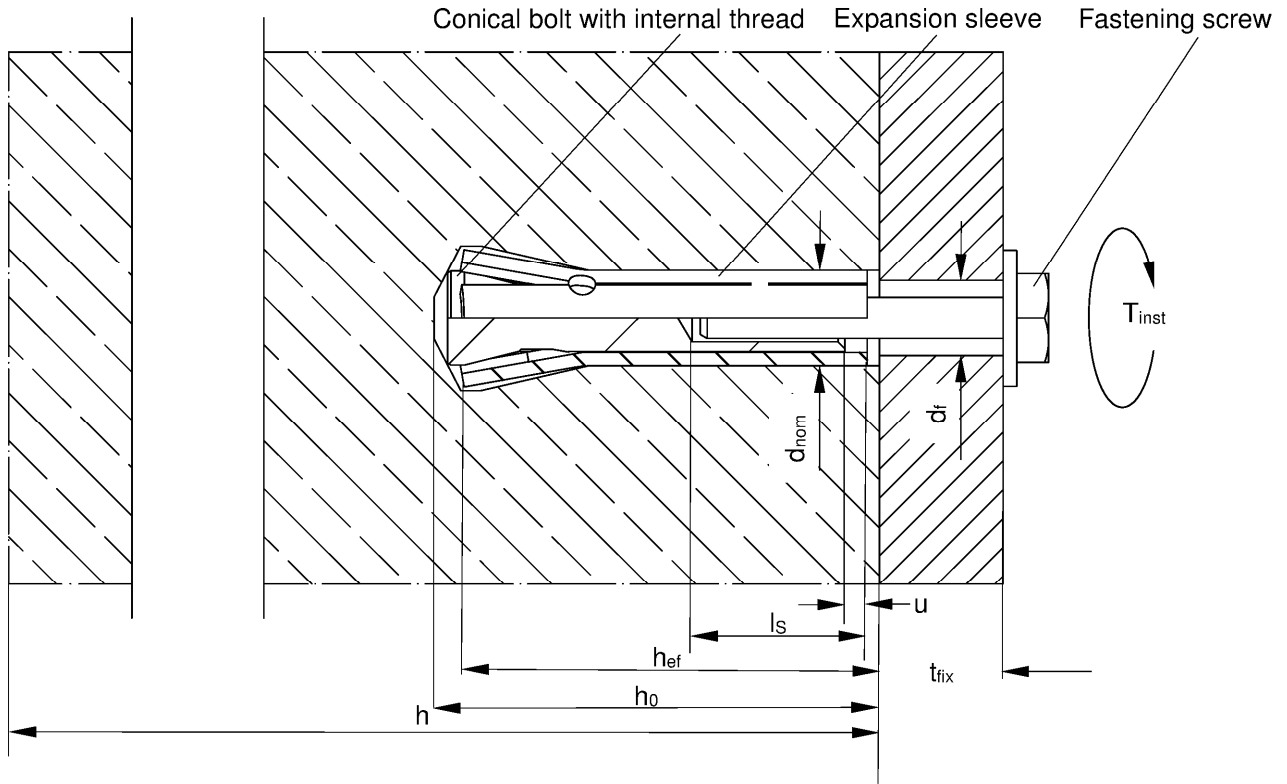

Bolt projecting anchor FZA ST:

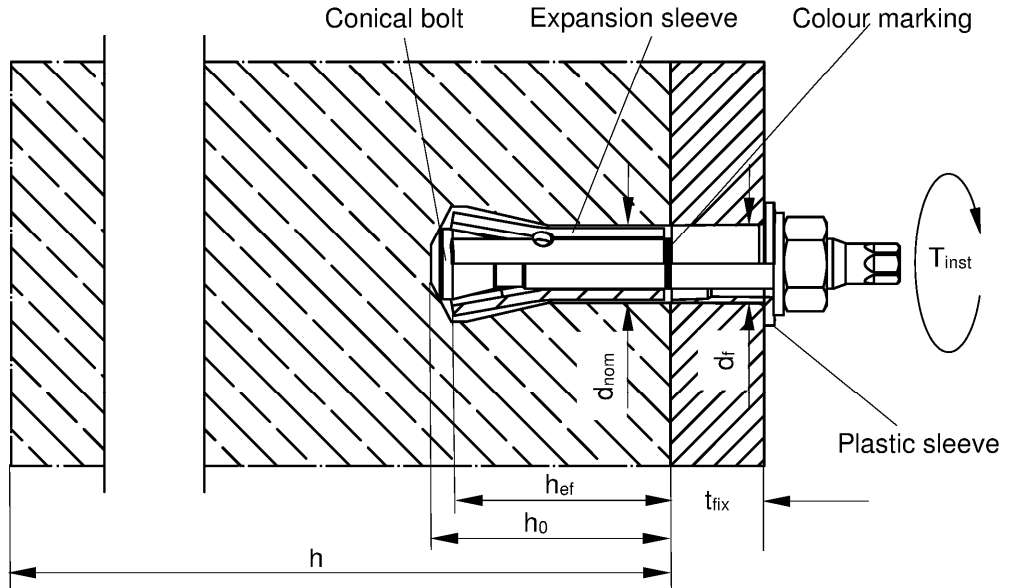

- Legend:
- h_{ef} = Effective embedment depth
 - t_{fix} = Thickness of fixture
 - d_r = Diameter of the clearance hole in the fixture
 - u = Gap between conical bolt with internal thread and expansion sleeve (FZA I)
 - h = Thickness of concrete member
 - T_{inst} = Required torque moment
 - l_s = Screwing depth
 - d_{nom} = Nominal anchor diameter
 - h_0 = Drill hole depth

(figure not to scale)

fischer-Zykon-Anchor FZA, FZA D, FZA I, FZA ST

Product description
Installed condition

Annex A2

Appendix 4/ 29

Type of anchors

Bolt projecting anchor

FZA:

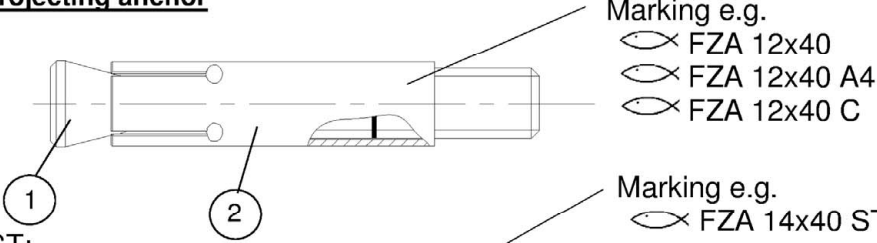

FZA ST:

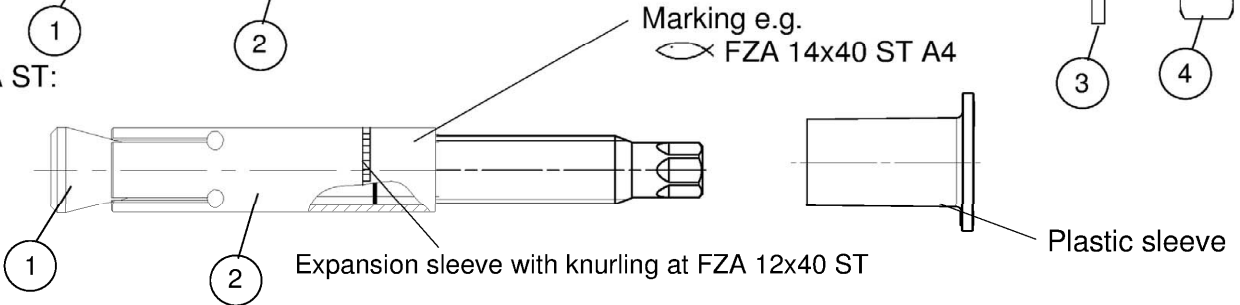

Through bolt anchor

FZA D:

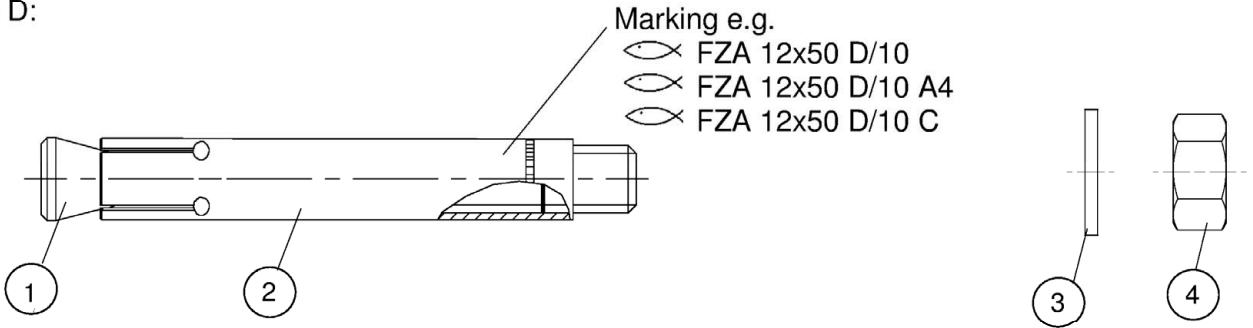

Internal thread anchor

FZA I:

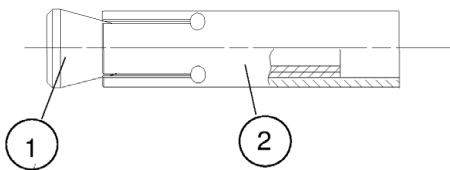

Related fastening screws respectively threaded rods must correspond to Annex A7 and with inspection certificate 3.1 acc. to EN 10204:2005-01

Zykon drill

FZUB:

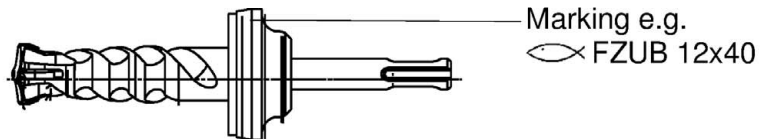

Setting tool FZE Plus

centring pin for internal thread anchor

Marking e.g. FZE 12 I

Marking e.g. FZE 12

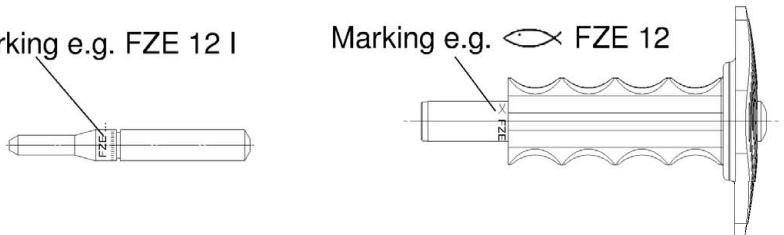

(figure not to scale)

fischer-Zykon-Anchor FZA, FZA D, FZA I, FZA ST

Product description
 Anchor Types and tools

Annex A3

Appendix 5/ 29

Types of expansion-sleeve

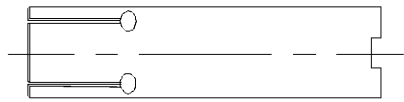

manufactured by punching

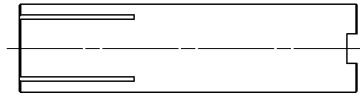

manufactured by turning

FZA

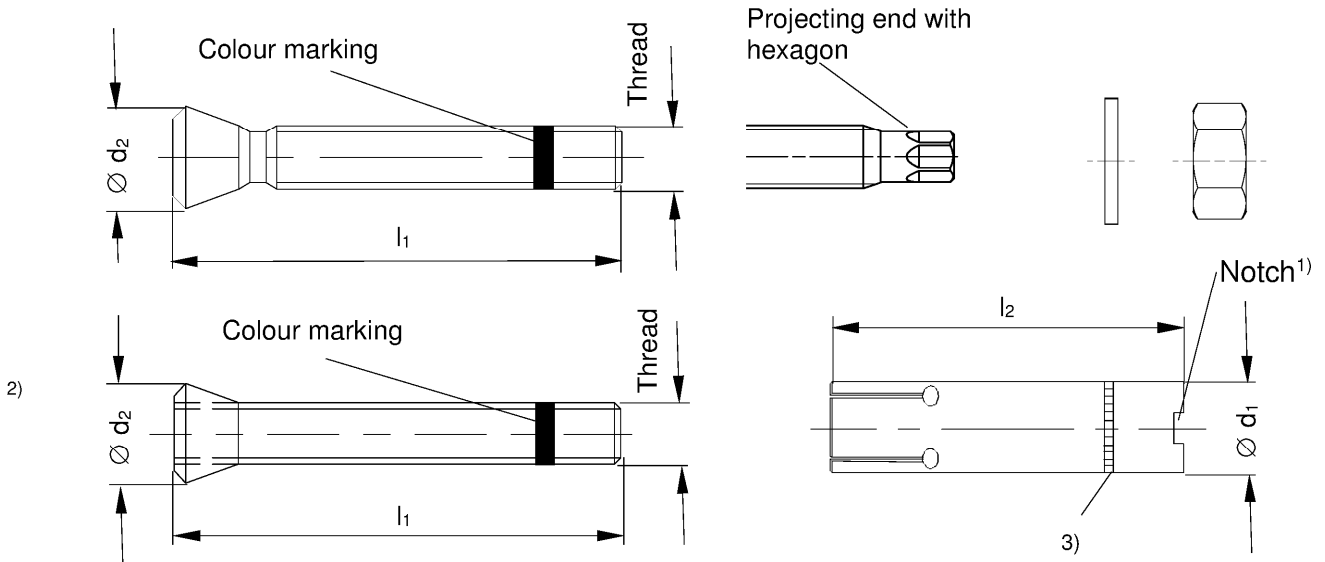

Table A4.1: Dimensions bolt projecting anchor FZA [mm]

Type of anchor	Thread	d	t _{fix} min	t _{fix} max	l ₁ min	l ₁ max	l ₂	∅ d ₁	∅ d ₂
FZA 10 x 40 M 6 / t _{fix} ¹⁾	M6	6	1	50	50	100	40	10	d ₂
FZA 12 x 40 M 8 / t _{fix} ¹⁾	M8	8		100	52	154		12	
FZA 14 x 40 M 10 / t _{fix} ¹⁾	M10	10		150	54	204		14	
FZA 12 x 50 M 8 / t _{fix}	M8	8		100	62	164	50	12	
FZA 14 x 60 M 10 / t _{fix}	M10	10		150	80	232	60	14	
FZA 18 x 80 M 12 / t _{fix}	M12	12		200	99	301	80	18	
FZA 22 x 100 M16 / t _{fix}	M16	16		250	122	374	100	22	
FZA 22 x 125 M16 / t _{fix} ¹⁾					147	399	125		
FZA 12 x 40 ST A4 ¹⁾	M8	8	1	100	62	164	50 ³⁾	12	
FZA 14 x 40 ST A4 ¹⁾	M10	10		150	54	204	40	14	
FZA 14 x 60 ST A4					80	232	60		

¹⁾ Expansion sleeve with notch

²⁾ Design: threaded bolt with cone nut

³⁾ Expansion sleeve with knurling at FZA 12x40 ST

(figure not to scale)

fischer-Zykon-Anchor FZA, FZA D, FZA I, FZA ST

Product description
Anchor dimensions

Annex A4

Appendix 6/ 29

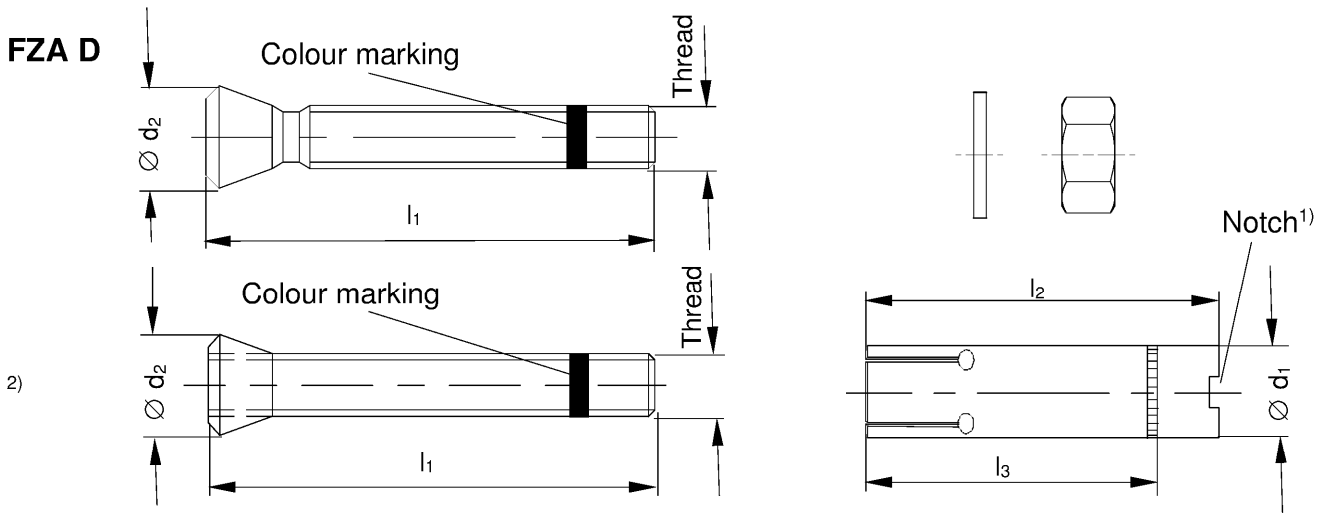

Table A5.1: Dimensions through bolt anchor FZA D [mm]

Type of anchor	Thread	d	t _{fix} min	t _{fix} max	l ₁	l ₂	l ₃	∅ d ₁	∅ d ₂
FZA 12 x 50 M 8 D / 10 ¹⁾	M8	8	1	10	69	50	40	12	
FZA 12 x 60 M 8 D / 10					79				
FZA 12 x 80 M 8 D / 30					30	99			
FZA 14 x 80 M 10 D / 20	M10	10	1	20	102	80	60	14	
FZA 14 x 100 M 10 D / 40					40				
FZA 18 x 100 M 12 D / 20	M12	12	1	20	126	100	80	18	
FZA 18 x 130 M 12 D / 50					50				
FZA 22 x 125 M 16 D / 25	M16	16	1	25	156	125	100	22	

¹⁾ Expansion sleeve with notch

²⁾ Design: threaded bolt with cone nut

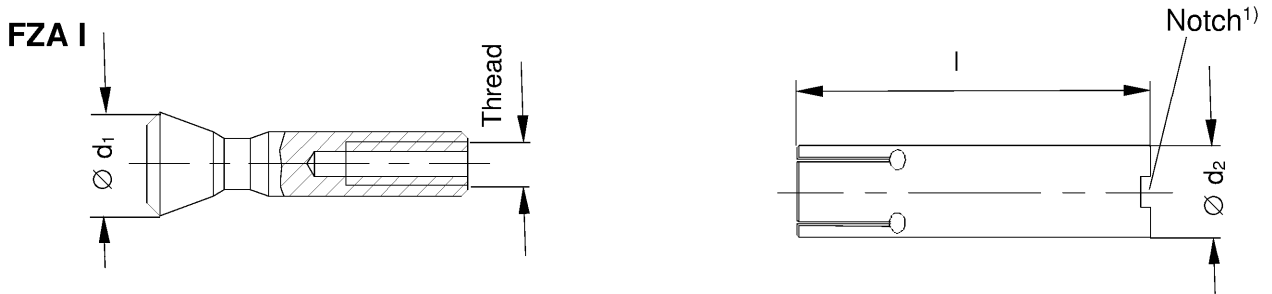

Table A5.2: Dimensions internal thread anchor FZA I [mm]

Type of anchor	Thread	d	∅ d ₁	∅ d ₂	l
FZA 12 x 40 M 6 I ¹⁾	M6	6	12		40
FZA 12 x 50 M 6 I					50
FZA 14 x 60 M 8 I	M8	8	14		60
FZA 18 x 80 M 10 I	M10	10	18		80
FZA 22 x 100 M 12 I	M12	12	22		100
FZA 22 x 125 M 12 I ¹⁾					125

¹⁾ Expansion sleeve with notch

(figure not to scale)

fischer-Zykon-Anchor FZA, FZA D, FZA I, FZA ST

Product description
Anchor dimensions

Annex A5

Appendix 7 / 29

Zykon drill FZUB

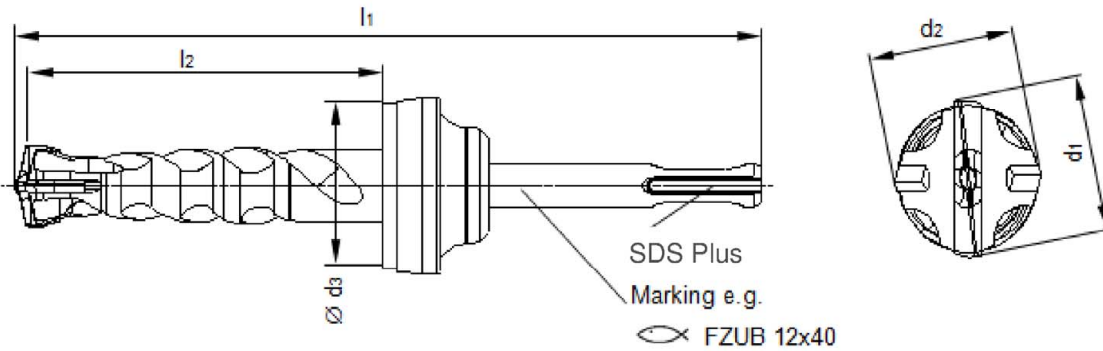
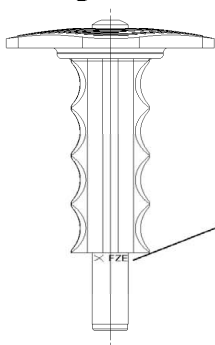

Table A6.1: Dimensions Zykon drill FZUB [mm]

Type of drill	Connection	l_1	$l_2 \geq$	d_1	d_2	$\varnothing d_3 \leq$
FZUB 10 x 40	SDS plus	126	40	10,35 - 10,80	$d_2 \leq d_1$	39,5
FZUB 12 x 40		127		12,45 - 12,85		
FZUB 12 x 50		137	50			
FZUB 12 x 60		147	60			
FZUB 12 x 80		167	80			
FZUB 14 x 40		130	40			
FZUB 14 x 60		152	60			
FZUB 14 x 80		172	80			
FZUB 14 x 100		192	100	18,75 - 19,15		
FZUB 18 x 80		172	80			
FZUB 18 x 100		192	100			
FZUB 18 x 130		222	130	22,45 - 22,95		
FZUB 22 x 100		197	100			
FZUB 22 x 125		222	125			43,5

Zykon drills FZUB and setting tools to use, acc. to Annex B2

Setting tool FZE Plus:



Marking e.g.
FZE 12

Optional fischer filling disc FFD for e.g. seismic C2 application:

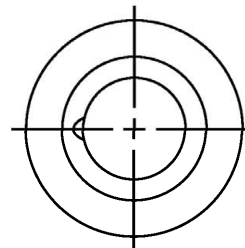

Centring pin for setting tool FZE Plus:

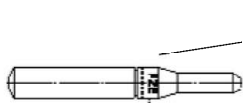

Marking e.g.
FZE 12 I

(figure not to scale)

fischer-Zykon-Anchor FZA, FZA D, FZA I, FZA ST

Product description

Zykon drill FZUB and setting tool FZE Plus

Annex A6

Appendix 8/ 29

Table A7.1: Materials FZA, FZA D, FZA I (zinc plated $\geq 5\mu\text{m}$, ISO 4042:2018)
FZA, FZA D (hot-dip galvanized ¹⁾, ISO 10684:2011)

Part	Designation	Material
1	Cone bolt with external thread	Cold form steel or free cutting steel Nominal steel tensile strength: $f_{uk} \leq 1000 \text{ N/mm}^2$
	Conical bolt with internal thread ²⁾	Steel, EN 10277:2018 Nominal steel tensile strength $f_{uk} \leq 1000 \text{ N/mm}^2$
2	Expansion sleeve seamless or rolled	Steel
3	Washer	Cold strip, EN 10139:2016
4	Hexagon nut	Steel, property class min. 8, ENISO 898-2:2012

Table A7.2: Materials FZA A4, FZA D A4, FZA I A4, FZA ST A4

Part	Designation	Material
1	Cone bolt with external thread	Stainless steel EN 10088:2014
	Conical bolt with internal thread ³⁾	
2	Expansion sleeve seamless or rolled	Stainless steel EN 10088:2014
3	Washer	
4	Hexagon nut	Stainless steel EN 10088:2014; ISO 3506-2:2018; property class – min. 70

Table A7.3: Materials FZA C, FZA D C, FZA I C

Part	Designation	Material
1	Cone bolt with external thread	High corrosion resistant steel EN 10088:2014
	Conical bolt with internal thread ⁴⁾	
2	Expansion sleeve seamless or rolled	
3	Washer	High corrosion resistant steel EN 10088:2014; ISO 3506-2:2018; property class – min. 70
4	Hexagon nut	

¹⁾ Alternative method sherardized, EN 13811:2003

²⁾ Related screws or threaded rods: property class 8.8 according to ENISO 898-1:2012; ductility $A_5 > 8\%$; zinc plated

³⁾ Related screws or threaded rods: property class ≥ 70 according to ENISO 3506-1:2018; ductility $A_5 > 8\%$; stainless steel 1.4401, 1.4404, 1.4578, 1.4571, 1.4439, 1.4362 according to EN 10088: 2014

⁴⁾ Related screws or threaded rods: property class ≥ 70 according to ENISO 3506-1:2018; ductility $A_5 > 8\%$; high corrosion resistant steel 1.4529, 1.4565 according to EN 10088:2014

fischer-Zykon-Anchor FZA, FZA D, FZA I, FZA ST

Product description
Materials

Annex A7

Appendix 9/ 29

Specifications of intended use

Anchorage subject to:

Size	FZA 10x40 FZA 12x40 FZA 12x40 ST FZA 12x50	FZA 14x40 FZA 14x40 ST FZA 14x60 FZA 14x60 ST FZA 18x80 FZA 22x100 FZA 22x125	FZA 12x50 D FZA 12x60 D FZA 12x80 D	FZA 14x80 D FZA 14x100 D FZA 18x100 D FZA 18x130 D FZA 22x125 D	FZA 12x40 I FZA 12x50 I FZA 14x60 I FZA 18x80 I FZA 22x100 I FZA 22x125 I
Static and quasi-static loads					
Cracked and uncracked concrete	✓		✓		✓
Fire exposure		✓		✓	
Seismic performance category	-		-		-

Base materials:

- Compacted reinforced or unreinforced normal weight concrete without fibers of strength classes C20/25 to C50/60 according to EN 206:2013+A1:2016

Use conditions (Environmental conditions):

- Structures subject to dry internal conditions
(Zinc plated steel, hot-dip galvanized steel, stainless steel, high corrosion-resistant steel)
- For all other conditions according to EN 1993-1-4:2006 + A1:2015 corresponding to corrosion resistance class
 - CRC III for FZA A4
 - CRC V for FZA C

Design:

- Anchorages are designed under the responsibility of an engineer experienced in anchorages and concrete work
- Verifiable calculation notes and drawings are to be prepared taking account of the loads to be anchored. The position of the anchor is indicated on the design drawings (e.g. position of the anchor relative to reinforcement or to supports, etc.)
- Design of fastenings according to EN 1992-4:2018

fischer-Zykon-Anchor FZA, FZA D, FZA I, FZA ST

Intended Use
Specifications

Annex B1

Appendix 10/ 29

Table B2.1: Installation parameters for FZA, FZA D, FZA I, FZA ST

Type of anchor	Drill hole depth $\geq h_0$ [mm]	Drill FZUB	Setting tool		$d_f^{2)}$ \leq [mm]	Torque moment ¹⁾ T_{inst} [Nm]	Gap u [mm]	Screwing depth l_s [mm]			
			FZE Plus					max	min		
FZA 10 x 40 M 6 / t_{fix}	43	10 x 40	10		7	8,5	-				
FZA 12 x 40 M 8 / t_{fix}		12 x 40	12		9	20					
FZA 14 x 40 M 10 / t_{fix}		14 x 40	14		12	40					
FZA 12 x 50 M 8 / t_{fix}	54	12 x 50	12		9	20					
FZA 14 x 60 M 10 / t_{fix}	63	14 x 60	14		12	40					
FZA 18 x 80 M 12 / t_{fix}	83	18 x 80	18		14	60					
FZA 22 x 100 M16 / t_{fix}	103	22 x 100	22		18	100					
FZA 22 x 125 M16 / t_{fix}	127	22 x 125									
FZA 12 x 40 ST A4	43	12 x 40	12	17	20	-					
FZA 14 x 40 ST A4		14 x 40	14								
FZA 14 x 60 ST A4	63	14 x 60									
FZA 12 x 50 M 8 D / 10	43	12 x 50	12	14	20	-					
FZA 12 x 60 M 8 D / 10	53	12 x 60									
FZA 12 x 80 M 8 D / 30		12 x 80									
FZA 14 x 80 M 10 D / 20	63	14 x 80	14	16	40						
FZA 14 x 100 M 10 D / 40		14 x 100									
FZA 18 x 100 M 12 D / 20	83	18 x 100	18	20	60						
FZA 18 x 130 M 12 D / 50		18 x 130									
FZA 22 x 125 M 16 D / 25	105	22 x 125	22	24	100						
FZA 12 x 40 M 6 I	43	12 x 40	12 + FZE 12 I	7	8,5				0 – 4,0	15	10
FZA 12 x 50 M 6 I	53	12 x 50									
FZA 14 x 60 M 8 I	63	14 x 60	14 + FZE 14 I	9	15	18	12				
FZA 18 x 80 M 10 I	83	18 x 80	18 + FZE 18 I	12	30	0 – 4,5	24	16			
FZA 22 x 100 M 12 I	103	22 x 100	22 + FZE 22 I	14	60						
FZA 22 x 125 M 12 I	127	22 x 125									

¹⁾ If the FZA with an internal thread (FZA I) is used with a threaded rod or a screw according to Annex A7 the torque moment must be applied as given in the table

²⁾ Diameter of the clearance hole in the fixture

fischer-Zykon-Anchor FZA, FZA D, FZA I, FZA ST

Intended Use
Installation parameters

Annex B2

Appendix 11/ 29

Installation instructions for FZA, FZA D, FZA I, FZA ST

- Anchor installation carried out by appropriately qualified personnel and under the supervision of the person responsible for technical matters of the site
- Use of the anchor only as supplied by the manufacturer without exchanging the components of the anchor
- Checking before placing the anchor to ensure that the strength class of the concrete in which the anchor is to be placed is in the range given and is not lower than that of the concrete to which the characteristic loads apply
- Check of concrete being well compacted, e.g. without significant voids
- Drill hole created perpendicular $\pm 5^\circ$ to concrete surface, positioning without damaging the reinforcement
- In case of aborted hole: new drilling at a minimum distance twice the depth of the aborted drill hole or smaller distance if the aborted drill hole is filled with high strength mortar and if under shear or oblique tension load it is not in the direction of load application
- Fastenings in stand-off installation or with a grout layer under seismic action are not covered
- In case of seismic applications, the fastener shall be positioned outside of critical regions (e.g. plastic hinges) of the concrete structure
- Anchor must be installed to comply with the correct anchorage depth. This is assured when the front face of the sleeve, for the internal thread, is approximately 1mm below the concrete surface or, in the case of the through bolt versions, approximately 1mm below the front surface of fixture. When using the FZA 12x40 ST the knurling on the sleeve is flush or below the concrete surface. For the bolt version the anchor is correctly expanded if the colour marking on the thread of the tapered bolt is visible.

fischer-Zykon-Anchor FZA, FZA D, FZA I, FZA ST

Intended Use
Installation instructions

Annex B3

Appendix 12/ 29

Pre-positioned installation

FZA

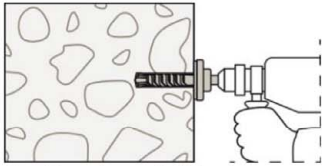

1.: Create a drill hole perpendicular to the surface of the anchor base with a hammer drill, using the corresponding Zykon universal drill bit FZUB. The required drill depth is reached once the FZUB depth stop meets the concrete.

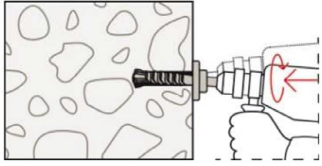

2.: Once the FZUB depth stop meets the concrete, create the drill hole undercut by making circular swiveling movements with the hammer drill while the hammer mechanism is engaged. Press the hammer drill firmly against the anchor base: 1 - 2 swiveling movements are sufficient for \varnothing 14 mm, with 3 - 5 movements for \varnothing 18 mm and \varnothing 22 mm.

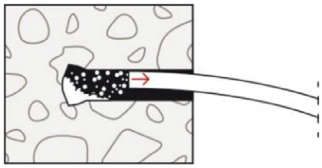

3.: Clean drill hole.

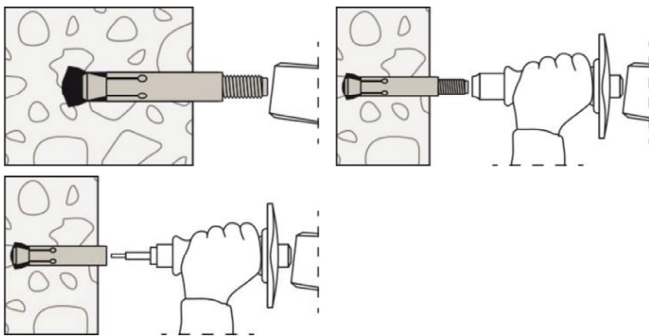

4.: Insert the anchor into the drill hole and then drive the expansion sleeve in with hammer-set device FZE Plus, using a manual hammer.

FZA I

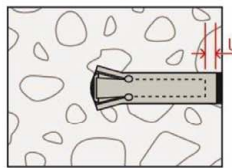
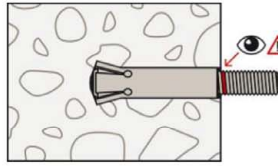

5.: The anchor is correctly expanded if the colour marking on the thread of the tapered bolt is visible or the gap u between conical bolt with internal thread and expansion sleeve (FZA I) is fulfilled. When using the FZA 12x40 ST the knurling on the sleeve is flush or below the concrete surface.

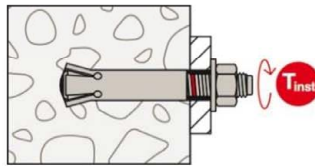

6.: Mount installation object (e.g. anchor plate), washer and nut, screw (for FZA I) or threaded rod with washer and nut (for FZA I) and apply installation torque with torque spanner.

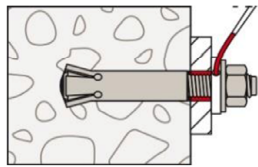

Optional: The gap between bolt and fixture may be filled with mortar (compressive strength ≥ 50 N/mm² e.g. FIS SB) after step 6 (for eliminating the annular gap). The filling disc is additional to the standard washer. The thickness of the filling disc must be considered for definition of t_{fix} . Countersunk of the filling disc in direction to the anchor plate.

fischer-Zykon-Anchor FZA, FZA D, FZA I, FZA ST

Intended Use
Installation instructions

Annex B4

Appendix 13/ 29

Push-through installation

FZA D

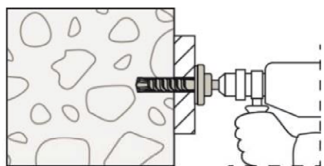

1.: Create a drill hole through the installation object perpendicular to the surface of the anchor base with a hammer drill, using the corresponding Zykon universal drill bit FZUB. The required drill depth is reached once the FZUB depth stop meets the fixture.

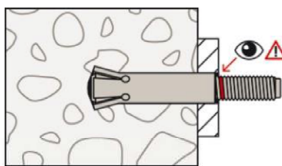

5.: The anchor is correctly expanded if the colour marking on the thread of the tapered bolt is visible.

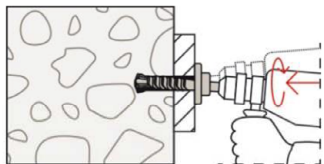

2.: Once the FZUB depth stop meets the fixture, create the drill hole undercut by making circular swiveling movements with the hammer drill while the hammer mechanism is engaged. Press the hammer drill firmly against the anchor base: 1 - 2 swiveling movements are sufficient for \varnothing 14 mm, with 3 - 5 movements for \varnothing 18 mm and \varnothing 22 mm.

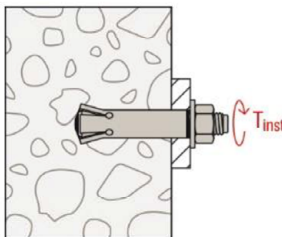

6.: Mount installation object (e.g. anchor plate), washer and nut and apply installation torque with torque spanner.

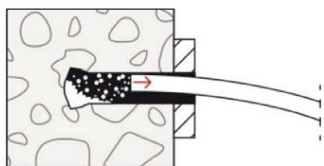

3.: Clean drill hole.

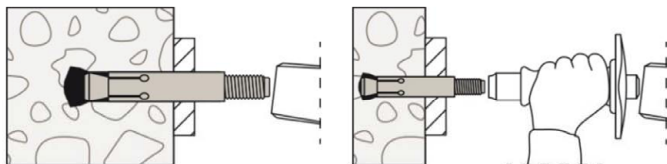

4.: Insert the anchor into the drill hole through the installation object (e.g. anchor plate) and then drive the expansion sleeve in with hammer-set device FZE Plus, using a manual hammer.

fischer-Zykon-Anchor FZA, FZA D, FZA I, FZA ST

Intended Use
Installation instructions

Annex B5

Appendix 14/ 29

Table C1.1: Characteristic values of **tension** resistance under static and quasi-static action for **bolt projecting anchor FZA**

Type of anchor / size	FZA (bolt projecting anchor)								
	10x40 M6 / t _{fix}	12x40 12x40 ST M8 / t _{fix}	14x40 14x40 ST M10 / t _{fix}	12x50 M8 / t _{fix}	14x60 14x60 ST M10 / t _{fix}	18x80 M12 / t _{fix}	22x100 M16 / t _{fix}	22x125 M16 / t _{fix}	
Steel failure for FZA galvanized									
Characteristic resistance	N _{Rk,s} [kN]	16,1	29,3	46,4	29,3	46,4	67,4	125,6	
Partial factor	γ _{Ms} [-]	1,5							
Steel failure for FZA hot-dip galvanized									
Characteristic resistance	N _{Rk,s} [kN]	13,1	25,0	40,7	25,0	40,7	60,1	115	
Partial factor	γ _{Ms} [-]	1,5							
Steel failure for FZA A4									
Characteristic resistance	N _{Rk,s} [kN]	14,1	25,6	40,6	25,6	40,6	59,0	109,9	
Partial factor	γ _{Ms} [-]	1,87							
Steel failure for FZA C									
Characteristic resistance	N _{Rk,s} [kN]	14,1	25,6	40,6	25,6	40,6	59,0	109,9	
Partial factor	γ _{Ms} [-]	1,5							
Modulus of elasticity	E _s [N/mm ²]	210.000							
Pullout failure for FZA, FZA A4, FZA C									
Characteristic resistance in concrete C20/25	cracked	N _{Rk,p} [kN]	6	9	12	24	40		
	uncracked	N _{Rk,p} [kN]	12	17,4	22,9	35,2	49,2	68,8	
Increasing factors concrete	ψ _c [-]	C25/30	1,12						
		C30/37	1,22						
		C35/45	1,32						
		C40/50	1,41						
		C45/55	1,50						
		C50/60	1,58						
Installation factor	γ _{inst} [-]	1,2			1,0				
Concrete cone failure and splitting failure for FZA, FZA A4, FZA C									
Effective embedment depth	h _{ef} [mm]	40			50	60	80	100	125
Factor for uncracked concrete	k _{ucr,N} [-]	11,0							
Factor for cracked concrete	k _{cr,N} [-]	7,7							
Minimum thickness of concrete member	h _{min}	100			110	130	160	200	250
Characteristic spacing	S _{cr,N} = S _{cr,sp} [mm]	3 h _{ef}							
Characteristic edge distance	C _{cr,N} = C _{cr,sp}	1,5 h _{ef}							
Characteristic resistance to splitting	N ⁰ _{Rk,sp} [kN]	min {N ⁰ _{Rk,c} ; N _{Rk,p} } ¹⁾							

¹⁾ N⁰_{Rk,c} according to EN 1992-4:2018

fischer-Zykon-Anchor FZA, FZA D, FZA I, FZA ST

Performances

Characteristic values of resistance under tension loads for bolt projecting anchor FZA

Annex C1

Table C2.1: Characteristic values of **tension** resistance under static and quasi-static action for **through bolt anchor FZA D**

Type of anchor / size	FZA D (through bolt anchor)							
	12x50 M8D/10	12x60 M8D/10	12x80 M8D/30	14x80 M10D/20	14x100 M10D/40	18x100 M12D/20	18x130 M12D/50	22x125 M16D/25
Steel failure for FZA D galvanized								
Characteristic resistance $N_{Rk,s}$ [kN]	29,3			46,4		67,4		125,6
Partial factor γ_{Ms} [-]	1,5							
Steel failure for FZA D hot-dip galvanized								
Characteristic resistance $N_{Rk,s}$ [kN]	25,0			40,7		60,1		115,0
Partial factor γ_{Ms} [-]	1,5							
Steel failure for FZA D A4								
Characteristic resistance $N_{Rk,s}$ [kN]	25,6			40,6		59,0		109,9
Partial factor γ_{Ms} [-]	1,87							
Steel failure for FZA D C								
Characteristic resistance $N_{Rk,s}$ [kN]	25,6			40,6		59,0		109,9
Partial factor γ_{Ms} [-]	1,5							
Modulus of elasticity E_s [N/mm ²]	210.000							
Pullout failure for FZA D, FZA D A4, FZA D C								
Characteristic resistance in concrete C20/25	cracked	$N_{Rk,p}$ [kN]	6	9	12	24	40	
	uncracked	$N_{Rk,p}$ [kN]	12	17,4	22,9	35,2	49,2	
Increasing factors concrete	ψ_c [-]	C25/30	1,12					
		C30/37	1,22					
		C35/45	1,32					
		C40/50	1,41					
		C45/55	1,50					
		C50/60	1,58					
Installation factor γ_{inst} [-]		1,2	1,0					
Concrete cone failure and splitting failure for FZA D, FZA D A4, FZA D C								
Effective embedment depth h_{ef} [mm]		40	50	60	80	100		
Factor for uncracked concrete $k_{ucr,N}$ [-]		11,0						
Factor for cracked concrete $k_{cr,N}$ [-]		7,7						
Minimum thickness of concrete member h_{min}		100	110	130	160	200		
Characteristic spacing $S_{cr,N} = S_{cr,sp}$ [mm]		3 h_{ef}						
Characteristic edge distance $C_{cr,N} = C_{cr,sp}$		1,5 h_{ef}						
Characteristic resistance to splitting $N^0_{Rk,sp}$ [kN]		$\min \{N^0_{Rk,c}; N_{Rk,p}\}^1$						

¹⁾ $N^0_{Rk,c}$ according to EN 1992-4:2018

fischer-Zykon-Anchor FZA, FZA D, FZA I, FZA ST

Performances

Characteristic values of resistance under tension loads for through bolt anchor FZA D

Annex C2

Table C3.1: Characteristic values of **tension** resistance under static and quasi-static action for **internal thread anchor FZA I**¹⁾

Type of anchor / size		FZA I (internal thread anchor)						
		12x40 M6 I	12x50 M6 I	14x60 M8 I	18x80 M10 I	22x100 M12 I	22x125 M12 I	
Steel failure for FZA I								
Characteristic resistance	$N_{Rk,s}$	[kN]	21,7	28,7	37,4	84,2		
Partial factor	γ_{Ms}	[-]	1,5					
Steel failure for FZA I A4								
Characteristic resistance	$N_{Rk,s}$	[kN]	22,2	26,8	34,9	61,7		
Partial factor	γ_{Ms}	[-]	1,5					
Steel failure for FZA I C								
Characteristic resistance	$N_{Rk,s}$	[kN]	19,4	26,8	34,9	78,5		
Partial factor	γ_{Ms}	[-]	1,5					
Modulus of elasticity	E_s	[N/mm ²]	210.000					
Pullout failure for FZA I, FZA I A4, FZA I C								
Characteristic resistance in concrete C20/25	cracked	$N_{Rk,p}$	[kN]	6	9	12	24	40
	uncracked			12	17,4	22,9	35,2	49,2
Increasing factors concrete	ψ_c	[-]	C25/30	1,12				
			C30/37	1,22				
			C35/45	1,32				
			C40/50	1,41				
			C45/55	1,50				
			C50/60	1,58				
Installation factor	γ_{inst}	[-]	1,2	1,0				
Concrete cone failure and splitting failure for FZA I, FZA I A4, FZA I C								
Effective embedment depth	h_{ef}	[mm]	40	50	60	80	100	125
Factor for uncracked concrete	$k_{ucr,N}$	[-]	11,0					
Factor for cracked concrete	$k_{cr,N}$		7,7					
Min. thickness of concrete member	h_{min}		100	110	130	160	200	250
Characteristic spacing	$s_{cr,N} = s_{cr,sp}$	[mm]	3 h_{ef}					
Characteristic edge distance	$c_{cr,N} = c_{cr,sp}$		1,5 h_{ef}					
Characteristic resistance to splitting	$N^0_{Rk,sp}$	[kN]	$\min \{N^0_{Rk,c}; N_{Rk,p}\}^2$					

¹⁾ Related screws or threaded rods see Annex A7

²⁾ $N^0_{Rk,c}$ according to EN 1992-4:2018

fischer-Zykon-Anchor FZA, FZA D, FZA I, FZA ST

Performances

Characteristic values of resistance under tension loads for internal thread anchor FZA I

Annex C3

Table C4.1: Characteristic values of **shear** resistance under static and quasi-static action for **bolt projecting anchor FZA**

Type of anchor / size		FZA (bolt projecting anchor)							
		10x40 M6 / t _{fix}	12x40 12x40 ST M8 / t _{fix}	14x40 14x40 ST M10 / t _{fix}	12x50 M8 / t _{fix}	14x60 14x60 ST M10 / t _{fix}	18x80 M12 / t _{fix}	22x100 M16 / t _{fix}	22x125 M16 / t _{fix}
Steel failure without lever arm FZA galvanized / hot-dip galvanized									
Characteristic resistance	$V_{Rk,s}^0$ [kN]	8,8	16,1	25,5	16,1	25,5	37,1	69,1	
Partial factor	γ_{Ms} [-]	1,25							
Factor for ductility	k_7	1,0							
Steel failure with lever arm FZA galvanized / hot-dip galvanized									
Characteristic bending resistance	$M_{Rk,s}^0$ [Nm]	12,2	30,0	59,8	30,0	59,8	104,8	266,4	
Partial factor	γ_{Ms} [-]	1,25							
Factor for ductility	k_7	1,0							
Steel failure without lever arm FZA A4									
Characteristic resistance	$V_{Rk,s}^0$ [kN]	9,2	16,7	26,4	16,7	26,4	38,4	76,9	
Partial factor	γ_{Ms} [-]	1,56							
Factor for ductility	k_7	1,0							
Steel failure with lever arm FZA A4									
Characteristic bending resistance	$M_{Rk,s}^0$ [Nm]	10,7	26,2	52,3	26,2	52,3	91,7	233,1	
Partial factor	γ_{Ms} [-]	1,56							
Factor for ductility	k_7	1,0							
Steel failure without lever arm FZA C									
Characteristic resistance	$V_{Rk,s}^0$ [kN]	9,2	16,7	26,4	16,7	26,4	38,4	76,9	
Partial factor	γ_{Ms} [-]	1,25							
Factor for ductility	k_7	1,0							
Steel failure with lever arm FZA C									
Characteristic bending resistance	$M_{Rk,s}^0$ [Nm]	10,7	26,2	52,3	26,2	52,3	91,7	233,1	
Partial factor	γ_{Ms} [-]	1,25							
Factor for ductility	k_7	1,0							
Concrete pryout failure FZA, FZA A4, FZA C									
Factor for pryout failure	k_8 [-]	1,3	2,4	1,3	3,1				
Concrete edge failure									
Effective length in concrete	l_f [mm]	40			50	60	80	100	125
Effective diameter of anchor	d_{nom}	10	12	14	12	14	18	22	
Installation factor	γ_{inst} [-]	1,0							
fischer-Zykon-Anchor FZA, FZA D, FZA I, FZA ST							Annex C4 Appendix 18/ 29		
Performances Characteristic values of resistance under shear loads for bolt projecting anchor FZA									

Table C5.1: Characteristic values of **shear** resistance under static and quasi-static action for **through bolt anchor FZA D**

Type of anchor / size	FZA D (through bolt anchor)							
	12x50 M8D/ 10	12x60 M8D/ 10	12x80 M8D/ 30	14x80 M10D/ 20	14x100 M10D/ 40	18x100 M12D/ 20	18x130 M12D/ 50	22x125 M16D/ 25
Steel failure without lever arm FZA D galvanized / hot-dip galvanized								
Characteristic resistance	$V_{Rk,s}^0$ [kN]	26,2		41,4		64,9		104,8
Partial factor	γ_{Ms} [-]	1,26						
Factor for ductility	k_7	1,0						
Steel failure with lever arm FZA D galvanized / hot-dip galvanized								
Characteristic bending resistance	$M_{Rk,s}^0$ [Nm]	30,0		59,8		104,8		266,4
Partial factor	γ_{Ms} [-]	1,25						
Factor for ductility	k_7	1,0						
Steel failure without lever arm FZA D A4								
Characteristic resistance	$V_{Rk,s}^0$ [kN]	30,4		43,2		88,3		141,0
Partial factor	γ_{Ms} [-]	1,96		1,92		1,56		
Factor for ductility	k_7	1,0						
Steel failure with lever arm FZA D A4								
Characteristic bending resistance	$M_{Rk,s}^0$ [Nm]	26,2		52,3		91,7		233,1
Partial factor	γ_{Ms} [-]	1,56						
Factor for ductility	k_7	1,0						
Steel failure without lever arm FZA D C								
Characteristic resistance	$V_{Rk,s}^0$ [kN]	30,4		43,2		88,3		141,0
Partial factor	γ_{Ms} [-]	1,85		1,79		1,44		1,46
Factor for ductility	k_7	1,0						
Steel failure with lever arm FZA D C								
Characteristic bending resistance	$M_{Rk,s}^0$ [Nm]	26,2		52,3		91,7		233,1
Partial factor	γ_{Ms} [-]	1,25						
Factor for ductility	k_7	1,0						
Concrete pryout failure FZA D, FZA D A4, FZA D C								
Factor for pryout failure	k_8 [-]	1,3		3,1				
Concrete edge failure								
Effective length in concrete	l_f [mm]	40	50	60	80	100		
Effective diameter of anchor	d_{nom}	12		14		18		22
Installation factor	γ_{inst} [-]	1,0						

fischer-Zykon-Anchor FZA, FZA D, FZA I, FZA ST

Performances

Characteristic values of resistance under shear loads for through bolt anchor FZA D

Annex C5

Table C6.1: Characteristic values of **shear** resistance under static and quasi-static action for **internal thread anchor FZA I¹⁾**

Type of anchor / size	FZA I (internal thread anchor)							
	12x40 M6 I	12x50 M6 I	14x60 M8 I	18x80 M10 I	22x100 M12 I	22x125 M12 I		
Steel failure without lever arm FZA I								
Characteristic resistance	$V_{Rk,s}^0$	[kN]	11,9	15,8	20,6	46,3		
Partial factor	γ_{Ms}	[-]	1,25					
Factor for ductility	k_7		1,0					
Steel failure with lever arm FZA I								
Characteristic bending resistance	$M_{Rk,s}^0$	[Nm]	19,3	30,1	44,7	150,9		
Partial factor	γ_{Ms}	[-]	1,25					
Factor for ductility	k_7		1,0					
Steel failure without lever arm FZA I A4								
Characteristic resistance	$V_{Rk,s}^0$	[kN]	14,4	17,4	22,7	43,2		
Partial factor	γ_{Ms}	[-]	1,25					
Factor for ductility	k_7		1,0					
Steel failure with lever arm FZA I A4								
Characteristic bending resistance	$M_{Rk,s}^0$	[Nm]	19,8	28,1	41,7	110,7		
Partial factor	γ_{Ms}	[-]	1,25					
Factor for ductility	k_7		1,0					
Steel failure without lever arm FZA I C								
Characteristic resistance	$V_{Rk,s}^0$	[kN]	12,6	17,4	22,7	55,0		
Partial factor	γ_{Ms}	[-]	1,25					
Factor for ductility	k_7		1,0					
Steel failure with lever arm FZA I C								
Characteristic bending resistance	$M_{Rk,s}^0$	[Nm]	17,3	28,1	41,7	140,8		
Partial factor	γ_{Ms}	[-]	1,25					
Factor for ductility	k_7		1,0					
Concrete pryout failure FZA I, FZA I A4, FZA I C								
Factor for pryout failure	k_8	[-]	1,3	3,1				
Concrete edge failure								
Effective length in concrete	l_f	[mm]	40	50	60	80	100	125
Effective diameter of anchor	d_{nom}		12	14	18	22		
Installation factor	γ_{inst}	[-]	1,0					

¹⁾ Related screws or threaded rods see Annex A7

fischer-Zykon-Anchor FZA, FZA D, FZA I, FZA ST

Performances

Characteristic values of resistance under shear loads for internal thread anchor FZA I

Annex C6

Table C7.1: Minimum thickness of concrete members, minimum spacings and minimum edge distances of bolt projecting anchor FZA

Type of anchor	FZA 10x40 M6 / t _{fix}	FZA 12x40 12x40 ST M8 / t _{fix}	FZA 14x40 14x40 ST M10 / t _{fix}	FZA 12x50 M8 / t _{fix}	FZA 14x60 14x60 ST M10 / t _{fix}	FZA 18x80 M12 / t _{fix}	FZA 22x100 M16 / t _{fix}	FZA 22x125 M16 / t _{fix}
Minimum spacing S_{min}	40		70	50	60	80	100	125
Minimum edge distance C_{min} [mm]	35	40		45	55	70		
Minimum thickness of concrete member h_{min}	100			110	130	160	200	250

Table C7.2: Minimum thickness of concrete members, minimum spacings and minimum edge distances of through bolt anchor FZA D

Type of anchor	FZA 12x50 M8 D/10	FZA 12x60 M8 D/10	FZA 12x80 M8 D/30	FZA 14x80 M10 D/20	FZA 14x100 M10 D/40	FZA 18x100 M12 D/20	FZA 18x130 M12 D/50	FZA 22x125 M16 D/25
Minimum spacing S_{min}	40	50		60		80		100
Minimum edge distance C_{min} [mm]	35	45		55		70		
Minimum thickness of concrete member h_{min}	100	110		130		160		200

Table C7.3: Minimum thickness of concrete members, minimum spacings and minimum edge distances of internal thread anchor FZA I

Type of anchor	FZA 12x40 M6 I	FZA 12x50 M6 I	FZA 14x60 M8 I	FZA 18x80 M10 I	FZA 22x100 M12 I	FZA 22x125 M12 I
Minimum spacing S_{min}	40	50	60	80	100	125
Minimum edge distance C_{min} [mm]	35	45	55	70		
Minimum thickness of concrete member h_{min}	100	110	130	160	200	250

fischer-Zykon-Anchor FZA, FZA D, FZA I, FZA ST

Performances

Minimum thickness of concrete members, minimum spacings and minimum edge distances

Annex C7

Table C8.1: Characteristic values for seismic performance category C1 for bolt projecting anchor FZA

Type of anchor / size	FZA (bolt projecting anchor)				
	14x40 M10 / t _{fix}	14x60 M10 / t _{fix}	18x80 M12 / t _{fix}	22x100 M16 / t _{fix}	22x125 M16 / t _{fix}
Steel failure FZA galvanized					
Characteristic resistance	N _{Rk,s,C1} [kN]	46,4	67,4	126	
Partial factor	γ _{Ms,C1} [-]	1,5			
Steel failure FZA hot-dip galvanized					
Characteristic resistance	N _{Rk,s,C1} [kN]	40,7	60,1	115	
Partial factor	γ _{Ms,C1} [-]	1,5			
Steel failure FZA A4					
Characteristic resistance	N _{Rk,s,C1} [kN]	40,6	59,0	110	
Partial factor	γ _{Ms,C1} [-]	1,87			
Steel failure FZA C					
Characteristic resistance	N _{Rk,s,C1} [kN]	40,6	59,0	110	
Partial factor	γ _{Ms,C1} [-]	1,5			
Pullout failure					
Characteristic resistance in cracked concrete	N _{Rk,p,C1} [kN]	6,0	20,0	40,0	
Installation factor	γ _{2,C1} [-]	1,0			
Steel failure without lever arm FZA					
Characteristic resistance	V _{Rk,s,C1} [kN]	20,9	33,8	62,8	
Partial factor	γ _{Ms,C1} [-]	1,25			
Steel failure without lever arm FZA A4					
Characteristic resistance	V _{Rk,s,C1} [kN]	18,3	29,5	55,0	
Partial factor	γ _{Ms,C1} [-]	1,56			
Steel failure without lever arm FZA C					
Characteristic resistance	V _{Rk,s,C1} [kN]	18,3	29,5	55,0	
Partial factor	γ _{Ms,C1} [-]	1,25			

Table C8.2: Annular gap for seismic action category C1

Δ _{gap}								
Δ _{gap} = d _f - d	[mm]	0,00 ¹⁾	0,25	0,50	0,75	1,00	1,25	≥ 1,50
α _{gap}		1,00	0,86	0,75	0,66	0,60	0,54	0,50

¹⁾ Filling of the Δ_{gap} according Annex B4

fischer-Zykon-Anchor FZA, FZA D, FZA I, FZA ST

Performances

Characteristic values for seismic performance category C1 for bolt projecting anchor FZA

Annex C8

Table C9.1: Characteristic values for seismic performance category C1 for through bolt anchor FZA D

Type of anchor / size	FZA D (through bolt anchor)				
	14x80 M10D/20	14x100 M10D/40	18x100 M12D/20	18x130 M12D/50	22x125 M16D/25
Steel failure FZA D galvanized					
Characteristic resistance	$N_{Rk,s,C1}$ [kN]	46,4		67,4	126
Partial factor	$\gamma_{Ms,C1}$ [-]	1,5			
Steel failure FZA D hot-dip galvanized					
Characteristic resistance	$N_{Rk,s,C1}$ [kN]	40,7		60,1	115
Partial factor	$\gamma_{Ms,C1}$ [-]	1,5			
Steel failure FZA D A4					
Characteristic resistance	$N_{Rk,s,C1}$ [kN]	40,6		59,0	110
Partial factor	$\gamma_{Ms,C1}$ [-]	1,87			
Steel failure FZA D C					
Characteristic resistance	$N_{Rk,s,C1}$ [kN]	40,6		59,0	110
Partial factor	$\gamma_{Ms,C1}$ [-]	1,5			
Pullout failure					
Characteristic resistance in cracked concrete	$N_{Rk,p,C1}$ [kN]	6,0		20,0	40,0
Installation factor	$\gamma_{2,C1}$ [-]	1,0			
Steel failure without lever arm FZA D					
Characteristic resistance	$V_{Rk,s,C1}$ [kN]	20,9		33,8	62,8
Partial factor	$\gamma_{Ms,C1}$ [-]	1,25			
Steel failure without lever arm FZA D A4					
Characteristic resistance	$V_{Rk,s,C1}$ [kN]	18,3		29,5	55,0
Partial factor	$\gamma_{Ms,C1}$ [-]	1,56			
Steel failure without lever arm FZA D C					
Characteristic resistance	$V_{Rk,s,C1}$ [kN]	18,3		29,5	55,0
Partial factor	$\gamma_{Ms,C1}$ [-]	1,25			

Table C9.2: Annular gap for seismic action category C1

Δ_{gap}							
$\Delta_{gap} = d_f - d_{nom}$ [mm]	0,00 ¹⁾	0,25	0,50	0,75	1,00	1,25	$\geq 1,50$
α_{gap}	1,00	0,86	0,75	0,66	0,60	0,54	0,50

¹⁾ Filling of the Δ_{gap} according Annex B4

fischer-Zykon-Anchor FZA, FZA D, FZA I, FZA ST

Performances

Characteristic values for seismic performance category C1 for through bolt anchor FZA D

Annex C9

Table C10.1: Characteristic values for seismic performance category C2 for bolt projecting anchor FZA

Type of anchor / size	FZA (bolt projecting anchor)					
	14x40 M10 / t _{fix}	14x60 M10 / t _{fix}	18x80 M12 / t _{fix}	22x100 M16 / t _{fix}	22x125 M16 / t _{fix}	
Steel failure FZA galvanized						
Characteristic resistance	N _{Rk,s,C2} [kN]	46,4	67,4	126,0		
Partial factor	γ _{Ms,C2} [-]	1,50				
Steel failure FZA hot-dip galvanized						
Characteristic resistance	N _{Rk,s,C2} [kN]	40,7	60,1	115,0		
Partial factor	γ _{Ms,C2} [-]	1,50				
Steel failure FZA A4						
Characteristic resistance	N _{Rk,s,C2} [kN]	40,6	59,0	110,0		
Partial factor	γ _{Ms,C2} [-]	1,87				
Steel failure FZA C						
Characteristic resistance	N _{Rk,s,C2} [kN]	40,6	59,0	110,0		
Partial factor	γ _{Ms,C2} [-]	1,50				
Pullout failure						
Characteristic resistance in cracked concrete	N _{Rk,p,C2} [kN]	6,0	7,5	24,0	25,0	40,0
Installation factor	γ _{2,C2} [-]	1,50				
Steel failure without lever arm FZA galvanized / hot-dip galvanized						
Characteristic resistance	V _{Rk,s,C2} [kN]	15,6	24,5	47,0		
Partial factor	γ _{Ms,C2} [-]	1,25				
Steel failure without lever arm FZA A4						
Characteristic resistance	V _{Rk,s,C2} [kN]	16,1	25,3	52,3		
Partial factor	γ _{Ms,C2} [-]	1,56				
Steel failure without lever arm FZA C						
Characteristic resistance	V _{Rk,s,C2} [kN]	16,1	25,3	52,3		
Partial factor	γ _{Ms,C2} [-]	1,25				

Table C10.2: Annular gap for seismic action category C2

Δ_{gap}								
Δ _{gap} = d _f - d	[mm]	0,00 ¹⁾	0,25	0,50	0,75	1,00	1,25	≥ 1,50
α _{gap}		1,00	0,86	0,75	0,66	0,60	0,54	0,50

¹⁾ Filling of the Δ_{gap} according Annex B4

fischer-Zykon-Anchor FZA, FZA D, FZA I, FZA ST

Performances

Characteristic values for seismic performance category C2 for bolt projecting anchor FZA

Annex C10

Appendix 24/ 29

Table C11.1: Characteristic values for seismic performance category C2 for through bolt anchor FZA D

Type of anchor / size	FZA D (through bolt anchor)					
	14x80 M10D/20	14x100 M10D/40	18x100 M12D/20	18x130 M12D/50	22x125 M16D/25	
Steel failure FZA D galvanized						
Characteristic resistance	$N_{Rk,s,C2}$ [kN]	46,4		67,4	126,0	
Partial factor	$\gamma_{Ms,C2}$ [-]	1,50				
Steel failure FZA D hot-dip galvanized						
Characteristic resistance	$N_{Rk,s,C2}$ [kN]	40,7		60,1	115,0	
Partial factor	$\gamma_{Ms,C2}$ [-]	1,50				
Steel failure FZA D A4						
Characteristic resistance	$N_{Rk,s,C2}$ [kN]	40,6		59,0	110,0	
Partial factor	$\gamma_{Ms,C2}$ [-]	1,87				
Steel failure FZA D C						
Characteristic resistance	$N_{Rk,s,C2}$ [kN]	40,6		59,0	110,0	
Partial factor	$\gamma_{Ms,C2}$ [-]	1,50				
Pullout failure						
Characteristic resistance in cracked concrete	$N_{Rk,p,C2}$ [kN]	6,0	7,5	24,0	25,0	40,0
Installation factor	$\gamma_{2,C2}$ [-]	1,50				
Steel failure without lever arm FZA D galvanized / hot-dip galvanized						
Characteristic resistance	$V_{Rk,s,C2}$ [kN]	15,6		24,5	47,0	
Partial factor	$\gamma_{Ms,C2}$ [-]	1,25				
Steel failure without lever arm FZA D A4						
Characteristic resistance	$V_{Rk,s,C2}$ [kN]	16,1		25,3	52,3	
Partial factor	$\gamma_{Ms,C2}$ [-]	1,56				
Steel failure without lever arm FZA D C						
Characteristic resistance	$V_{Rk,s,C2}$ [kN]	16,1		25,3	52,3	
Partial factor	$\gamma_{Ms,C2}$ [-]	1,25				

Table C11.2: Annular gap for seismic action category C2

Δ_{gap}							
$\Delta_{gap} = d_f - d_{nom}$ [mm]	0,00 ¹⁾	0,25	0,50	0,75	1,00	1,25	$\geq 1,50$
α_{gap}	1,00	0,86	0,75	0,66	0,60	0,54	0,50

¹⁾ Filling of the Δ_{gap} according Annex B4

fischer-Zykon-Anchor FZA, FZA D, FZA I, FZA ST

Performances

Characteristic values for seismic performance category C2 for through bolt anchor FZA D

Annex C11

Appendix 25/ 29

Table C12.1: Characteristic values for resistance to fire¹⁾

FZA galvanized		10x40 M6 12x40 M6 I 12x50 M6 I	12x40 M8 12x40 ST M8 12x50 M8 D/10	12x50 M8 12x60 M8 D/10 12x80 M8 D/30 14x60 M8 I 18x80 M10 I	14x40 M10 14x40 ST M10
Steel failure for tension load and shear load ($F_{Rk,s,fi} = N_{Rk,s,fi} = V_{Rk,s,fi}$)					
Characteristic resistance	$F_{Rk,s,fi}$ [kN]	R30	1,2	2,2	5,2
		R60	0,7	1,3	2,6
		R90	0,5	1,0	1,8
		R120		0,8	1,3
	$M^0_{Rk,s,fi}$ [Nm]	R30	0,9	2,3	6,7
		R60	0,5	1,3	3,4
		R90	0,4	1,0	2,3
		R120		0,9	1,7
Pullout failure					
Characteristic resistance	$N_{Rk,p,fi}$ [kN]	R30	1,5	2,3	1,5
		R60			
		R90			
		R120	1,2	1,8	1,2
FZA galvanized		14x60 M10 14x60 ST M10 14x80 M10 D/20 14x100 M10 D/40	18x80 M12 18x100 M12 D/20 18x130 M12 D/50 22x100 M12 I 22x125 M12 I	22x100 M16 22x125 M16 D/25	22x125 M16
Steel failure for tension load and shear load ($F_{Rk,s,fi} = N_{Rk,s,fi} = V_{Rk,s,fi}$)					
Characteristic resistance	$F_{Rk,s,fi}$ [kN]	R30	5,2	7,5	13,9
		R60	2,6	3,8	7,0
		R90	1,8	2,5	4,7
		R120	1,3	1,9	3,6
	$M^0_{Rk,s,fi}$ [Nm]	R30	6,7	11,6	29,5
		R60	3,4	5,9	14,9
		R90	2,3	4,0	10,0
		R120	1,7	3,0	7,6
Pullout failure					
Characteristic resistance	$N_{Rk,p,fi}$ [kN]	R30	3,0	5,0	10,0
		R60			
		R90			
		R120	2,4	4,0	8,0
Edge distance					
R30 to R120	$C_{cr,fi}$ [mm]	-	$2 \cdot h_{ef}$		
In case of fire attack from more than one side, the minimum edge distance shall be ≥ 300 mm					
Spacing					
R30 to R120	$s_{cr,fi}$ [mm]	-	$2 \cdot C_{cr,fi}$		
¹⁾ The embedment depth has to be increased for wet concrete by at least 30 mm compared to the given value					
fischer-Zykon-Anchor FZA, FZA D, FZA I, FZA ST					Annex C12 Appendix 26/ 29
Performances Characteristic values for resistance to fire					

Table C13.1: Characteristic values for resistance to fire¹⁾

FZA A4 / C		10x40 M6 12x40 M6 I 12x50 M6 I	12x40 M8 12x40 ST M8 12x50 M8 D/10	12x50 M8 12x60 M8 D/10 12x80 M8 D/30 14x60 M8 I 18x80 M10 I	14x40 M10 14x40 ST M10
Steel failure for tension load and shear load ($F_{Rk,s,fi} = N_{Rk,s,fi} = V_{Rk,s,fi}$)					
Characteristic resistance	$F_{Rk,s,fi}$ [kN]	R30	2,0	3,6	5,7
		R60	1,2	2,3	3,6
		R90	0,9	1,9	3,0
		R120	0,7	1,6	2,6
	$M^0_{Rk,s,fi}$ [Nm]	R30	1,5	3,7	7,4
		R60	0,9	2,4	4,7
		R90	0,7	1,9	3,8
		R120	0,5	1,7	3,4
Pullout failure					
Characteristic resistance	$N_{Rk,p,fi}$ [kN]	R30	1,5	2,3	1,5
		R60			
		R90			
		R120	1,2	1,8	1,2
FZA A4 / C		14x60 M10 14x60 ST M10 14x80 M10 D/20 14x100 M10 D/40	18x80 M12 18x100 M12 D/20 18x130 M12 D/50 22x100 M12 I 22x125 M12 I	22x100 M16 22x125 M16 D/25	22x125 M16
Steel failure for tension load and shear load ($F_{Rk,s,fi} = N_{Rk,s,fi} = V_{Rk,s,fi}$)					
Characteristic resistance	$F_{Rk,s,fi}$ [kN]	R30	5,7	11,8	22,0
		R60	3,6	7,0	13,1
		R90	3,0	5,5	10,2
		R120	2,6	4,7	8,7
	$M^0_{Rk,s,fi}$ [Nm]	R30	7,4	18,3	46,6
		R60	4,7	10,9	27,9
		R90	3,8	8,5	21,6
		R120	3,4	7,3	18,5
Pullout failure					
Characteristic resistance	$N_{Rk,p,fi}$ [kN]	R30	3,0	5,0	10,0
		R60			
		R90			
		R120	2,4	4,0	8,0
Edge distance					
R30 to R120	$C_{cr,fi}$ [mm]	-	$2 \cdot h_{ef}$		
In case of fire attack from more than one side, the minimum edge distance shall be ≥ 300 mm					
Spacing					
R30 to R120	$s_{cr,fi}$ [mm]	-	$2 \cdot C_{cr,fi}$		
¹⁾ The embedment depth has to be increased for wet concrete by at least 30 mm compared to the given value					
fischer-Zykon-Anchor FZA, FZA D, FZA I, FZA ST					Annex C13 Appendix 27/ 29
Performances Characteristic values for resistance to fire					

Table C14.1: Displacements due to tension loads for bolt projecting anchor FZA

Type of anchor / size		FZA (bolt projecting anchor)						
		10x40 M6 / t _{fix}	12x40 M8 / t _{fix}	14x40 M10 / t _{fix}	12x50 M8 / t _{fix}	14x60 M10 / t _{fix}	18x80 M12 / t _{fix}	22x100 M16 / t _{fix}
Tension load in cracked concrete	N [kN]	2,0		3,5	5,0	8,0	16,0	
Displacement	$\frac{\delta_{N0}}{\delta_{N\infty}}$ [mm]	0,8						
		1,1						
Tension load in uncracked concrete	N [kN]	3,3		4,8	7,5	12,7	17,9	
Displacement	$\frac{\delta_{N0}}{\delta_{N\infty}}$ [mm]	0,8						
		1,1						

The displacements do not apply for FZA ST

Table C14.2: Displacements due to tension loads for through bolt anchor FZA D

Type of anchor / size		FZA D (through bolt anchor)						
		12x50 M8D/ 10	12x60 M8D/ 10	12x80 M8D/ 30	14x80 M10D/ 20	14x100 M10D/ 40	18x100 M12D/ 20	18x130 M12D/ 50
Tension load in cracked concrete	N [kN]	2,0	3,5		5,0		8,0	16,0
Displacement	$\frac{\delta_{N0}}{\delta_{N\infty}}$ [mm]	0,8						
		1,1						
Tension load in uncracked concrete	N [kN]	3,3	4,8		7,5		12,7	17,9
Displacement	$\frac{\delta_{N0}}{\delta_{N\infty}}$ [mm]	0,8						
		1,1						

Table C14.3: Displacements due to tension loads for internal thread anchor FZA I

Type of anchor / size		FZA I (internal thread anchor FZA I)					
		12x40 M6 I	12x50 M6 I	14x60 M8 I	18x80 M10 I	22x100 M12 I	22x125 M12 I
Tension load in cracked concrete	N [kN]	2,0	3,5	5,0	8,0	16,0	
Displacement	$\frac{\delta_{N0}}{\delta_{N\infty}}$ [mm]	0,8					
		1,1					
Tension load in uncracked concrete	N [kN]	3,3	4,8	7,5	12,7	17,9	
Displacement	$\frac{\delta_{N0}}{\delta_{N\infty}}$ [mm]	0,8					
		1,1					

fischer-Zykon-Anchor FZA, FZA D, FZA I, FZA ST

Performances

Displacements due to tension loads

Annex C14

Table C15.1: Displacements due to shear loads for bolt projecting anchor FZA and through bolt anchor FZA D

Type of anchor / size	FZA (bolt projecting anchor) and FZA D (through bolt anchor)							
	10x40 M6 / t _{fix}	14x40 M10 / t _{fix}	12x40 M8 / t _{fix}	12x50 M8 / t _{fix}	12x50 M8D/10	12x60 M8D/10	12x80 M8D/30	14x80 M10D/20
Shear load in cracked and uncracked concrete	V [kN]	4,0	9,0	5,0				12,5
Displacement	$\frac{\delta_{V0}}{\delta_{V\infty}}$ [mm]	2,0	1,9	0,7				1,9
		3,0	2,8	1,0				2,8
Type of anchor / size	FZA (bolt projecting anchor) and FZA D (through bolt anchor)							
	14x60 M10 / t _{fix}	14x100 M10D/ 40	18x80 M12 / t _{fix}	18x100 M12D/ 20	18x130 M12D/ 50	22x100 M16 / t _{fix}	22x125 M16 / t _{fix}	22x125 M16D/ 25
Shear load in cracked and uncracked concrete	V [kN]	12,5	12,5	19,0			30,0	
Displacement	$\frac{\delta_{V0}}{\delta_{V\infty}}$ [mm]	1,9		2,1				
		2,8		3,1				

The displacements do not apply for FZA ST

Table C15.2: Displacements due to shear loads for internal thread anchor FZA I

Type of anchor / size	FZA I (internal thread anchor)					
	12x40 M6 I	12x50 M6 I	14x60 M8 I	18x80 M10 I	22x100 M12 I	22x125 M12 I
Shear load in cracked and uncracked concrete	V [kN]	5,0		12,5	19,0	30,0
Displacement	$\frac{\delta_{N0}}{\delta_{N\infty}}$ [mm]	0,7		1,9	2,1	
		1,0		2,8	3,1	

Table C15.3: Displacements due to tension and shear loads for seismic performance category C2 for FZA and FZA D

Type of anchor / size	FZA (bolt projecting anchor) and FZA D (through bolt anchor)				
	14x40 M10	14x60 M10 14x80 M10 D 14x100 M10 D	18x80 M12 18x100 M12 D 18x130 M12 D	22x100 M16 22x125 M16 D	22x125 M16
Displacement	$\frac{\delta_{N,C2(DLS)}}{\delta_{N,C2(ULS)}} \quad \frac{\delta_{V,C2(DLS)}}{\delta_{V,C2(ULS)}} \quad$ [mm]	3,8		4,7	4,9
		13,5		12,7	13,1
		4,3		4,6	5,0
		6,9		7,0	6,9

fischer-Zykon-Anchor FZA, FZA D, FZA I, FZA ST

Performances

Displacements due to shear loads

Displacements due to tension and shear loads for seismic performance category C2

Annex C15